

# Multiple shots on SPDs - Test Methods and Results

Alain Rousseau  
SEFTIM

Vincennes, France  
alain.rousseau@seftim.fr

Xuyun Zang  
Shanghai GrandTop  
Lightning

Shanghai, China  
xuyun.zang@grandtop.cn

Lihua Zhang  
Beijing SPDs Test Center

Beijing, China

Ming Tao  
Eurotect Electrical,

Ecully, France  
eurotect123@free.fr

**Abstract**— The lightning threat becomes more and more severe in low voltage power system especially in electronics and telecommunication system. The surge protection devices (SPDs) are used as common protective measures. Single pulse is the main test method described in standards. Now a new build 10-pulse generator to simulate the natural stroke with multiple pulses provides other method to test the internal components, structure and the protection ability of SPDs. The paper introduces the purpose of the test, the test system and the first stage test results

**Keywords**-SPDs; tests, multiple pulse

## I. INTRODUCTION

There are many evidences [1], [2], [3] (see also tests performed by Matt Darveniza from one side and Rick Gumley from another side presented in previous IEC meetings) that multiple shots can create problem to varistors. The time interval for multiple strokes is typically around 30 ms to 100 ms. Previous tests have shown that varistors that withstand many tens of kA can only handle a few kA when repetitive strokes are injected. The measured lightning current (as shown in Fig. 1) from a tower in south China shows that lightning is a continuous process with multiple pulses [1].

When a multiple stroke lightning flash occurs on a line the attachment point may move but will probably remain located on the line itself. It is the same for lightning striking a structure in vicinity of the line for example a tree.

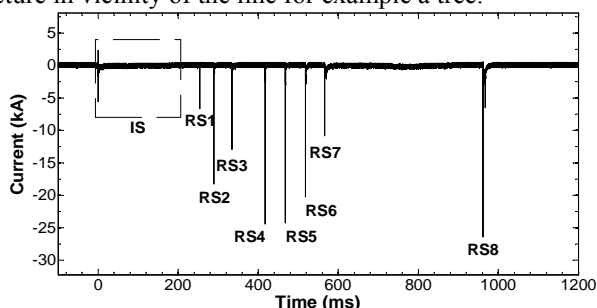

Figure 1. measured lightning current in natural conditions

The surges that will propagate on the line will then arrive at the SPF located at the entrance of the installation at various moments depending on the time spacing between two strokes.

Typical surge to considers are in the range of 1 kA to 5 kA with an 8/20 wave for induced events and a wave shape 10/350 could also be used in case of direct strike on the line.

First purpose of the study is to check what is the status with the typical varistors made today to improve the energy withstands: how they behave, what about the evolution of the residual voltage as well as the reference voltage at 1 mA.

The second purpose is to check the behavior of all type of SPD including trigger spark gaps and combination type SPD where the effect of such multiple pulses could exist not only to degrade or age the varistors but also other components that may be not directly connected to the main protection function but to a subsidiary function that may affect the long term behavior of the SPD.

The single pulse is used for testing the SPDs according IEC standards. It covers most of the surges in low power system but can't satisfy the lightning stroke measured in Europe, Canada and China. A lightning generator with multiple pulses to simulate the continuous flash will check the SPDs failure modes in actual surge stress.

## II. INTRODUCTION OF THE GENERATOR

A ten-pulse test system has been built in BJSTC (Beijing Surge Protection Device Test Center). It can simulate induced lightning impulse currents. The parameter of the waveform is 8/20  $\mu$ s defined in the standards IEC 60060-1 and IEC61643-11. The 8/20  $\mu$ s peak current range is from several kA to 100 kA and the interval time of the pulse can be changed from 1 ms to 999 ms. The maximum peak of the first and the tenth pulse is 100 kA and the other pulses between them are 50 kA. The generator has 10 independent discharge circuits which are triggered by ten time-controlled trigger channels. The computer and the trigger channels are connected by optical fiber. The discharge interval can be setup on the screen. The trigger unit diagram is shown in Fig. 2.

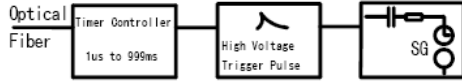

Figure 2. time-controller and the trigger unit

There are two charging units, with maximum voltage 110kV and charging current 0.25A, controlled by two independent consoles. The console can set the charging voltage to change the charging speed. The two controlling system can cooperate on a server-customer mode to deliver the 10 pulses at the output.

The multiple pulses generator is combined with two parts: every part has its charging unit, five capacitor banks, and five discharge units. The ten discharge circuits can be triggered asynchronously with different time interval into a flash sequence or discharge synchronously into a high peak impulse current, up to 450kA. The capacitor bank for the first and the last pulse is 13.2 $\mu$ F and other banks are 6.6 $\mu$ F with charging voltage 110kV. The design of the generator is open for other types of waveform such as 2/40 $\mu$ s and 10/350 $\mu$ s with crowbar circuit for future development. Fig. 3 shows the diagram of the generator and Fig. 4 and 5 show the generator itself as well as its operation.

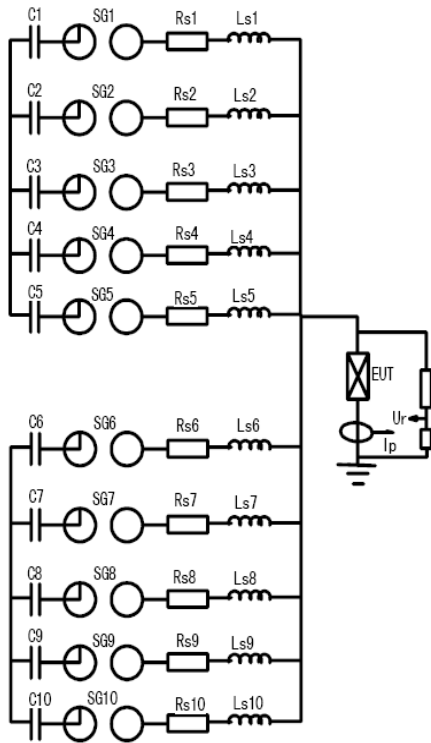

Figure 3. Diagram of the multiple pulses generator



Figure 4. View of the multiple pulses Generator

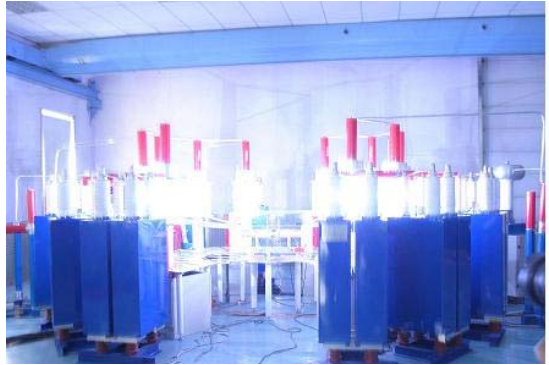

Figure 5. Ten flashes simulating the return stroke

The lightning current is transferred from a Rogowski Coil (from Pearson) to a Tektronics DPO3054. A precision resistance divider is used for measure the residual voltage.

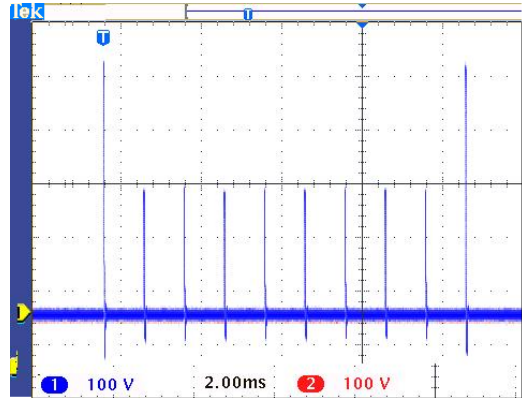

Figure 6. Ten pulses oscilloscope (10kA:100V)

### III. TEST METHOD AND RESULTS

From the observations of lightning stroke, the last flash peak has the large value [1], [2],[4] and [5]. The multiple pulses test is then designed as a ten impulse sequence: the peak of the first one and the last one is two times of the other eight impulses.

TABLE I. THE PEAK VALUES OF THE PULSE SEQUENCE

Component	Peak kA	Waveform
First impulse	100	8/20 $\mu$ s
2 <sup>nd</sup> -9 <sup>th</sup> impulse	50	8/20 $\mu$ s
tenth impulse	100	8/20 $\mu$ s

The output current peak will change with the charging voltage changing. The ratio of the 1st and 10th peak value to the middle eight peaks is always 2 times.

Varistors are one of the basic elements in SPDs. It is known that multiple pulses will destroy the varistors because of the thermal effects. Fig. 7 shows that the time of the clamping voltage lasts more than 2ms. If the interval time is short than 2ms the current in MOV will be continuous.

The parallel connected varistors design is used in SPDs to enlarge the load current ability. The design is working well when the current is balanced between the different varistors. The nominal discharge current of the sample SPDs is 80kA 8/20 $\mu$ s. The interval time of the pulse is 2ms. The maximum peak current of the first pulse is 40kA 8/20 $\mu$ s and the followed pulse is 20kA. The sample is bearing the first ten current impulses but fails in the second sequence.

The operation on duty test on MOV is combined with 8/20 $\mu$ s and AC voltage. The multiple pulses generator will be triggered synchronously to the power frequency voltage. The trigger unit is starting to discharge the first impulse current, and the following discharge circuit is triggered by the timer setting. The phase angle can be changed according the IEC standards, e.g. with 30 $^\circ$ step. The generator can trigger not only the multiple current impulses at the same angle, but also the different angle. This can simulate the realistic lightning stroke in nature better.

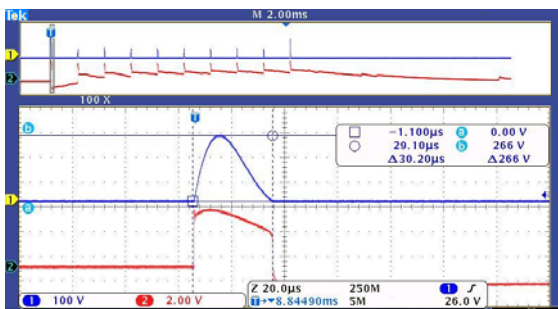

Figure 7. 10-pulses current and clamping voltage waveform on a MOV-type SPD (Ch1: 10kA/100V, Ch2: 1kV/1V)

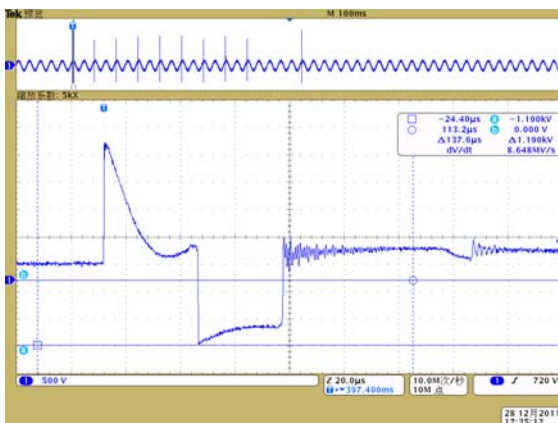

Figure 8. 10-pulses voltage waveform on a MOV-type SPD (Ch1: 500V/grid)

The pulse number, the time interval and the peak current value are the main important factors in the multiple pulses test. The waveform type is also the other important factor. The failure mode is different from the multiple pulses changes. One interesting test is with ten current impulses on a MOV type SPDs which  $I_{max}=200$  kA. The parallel varistors are OK but the connection near the MOV failed. The maximum peak current is 100kA. The test discovers some new performance in the multiple pulses test.

The gap type SPDs is also used in power system. The gap will conduct the current when surge comes and cut the follow current. Fig. 9 shows the test result of a gap SPDs stroked by a multiple pulses.

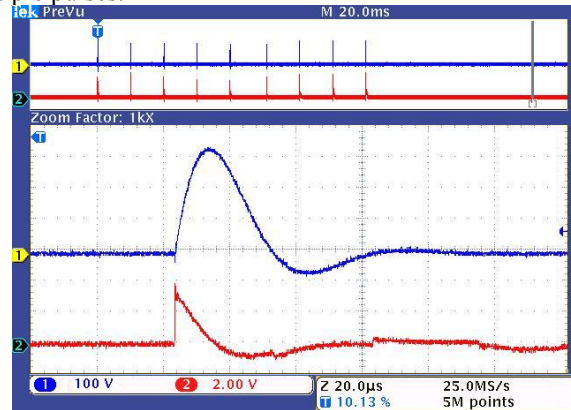

Figure 9. Ten pulses current and voltage of gap-type SPD (Ch1: 10kA/100V, Ch2: 1kV/1V)

#### IV. CONCLUSIONS

Research made originally in Australia has shown that multiple pulses may damage some SPDs at lower levels than the maximum discharge current. Such a way of testing has been proposed in the way of development of IEC SPD standards but has not originally being retained as a basic main test. However, measurement on natural lightning shows that such multiple pulses exist and a new generator has been developed in China to cover this need. Tests on various SPDs design are being performed in order to show how this stress can influence the SPD energy withstand and its failure modes. Purpose of this contribution is to be a preliminary step for possible inclusion of such a test in SPD standards. Further tests need to be performed at lower currents and also with more technologies, especially technologies combining varistors and spark gaps. The preliminary tests demonstrate that the generator is easy to operate and flexible in multiple pulses simulation.

#### REFERENCES

[1] YANG Shao-jie, CHEN Shao-dong, ZHANG Yi-jun, et al. Characteristics analysis of the induced overcurrent generated by close triggered lightning on the overhead transmission power line [J]. Journal of Tropical Meteorology, 2010, 16(1): 59-65.

- [2] Heidler F, Flisowski Z, Zischank W, et al. Parameters of lightning current given on IEC62305-Background, experimental outlook[C]//29th International Conference on Lightning Protect. Uppsala, Sweden, 2008:
- [3] Berger K. Novel observation on lightning discharge: Results of research on Mount San Salvatore [J]. Journal of the Franklin Institute, 1967, 283(6): 478-525.
- [4] MIL-STD-464A, electromagnetic environmental effects Requirements for systems[S], 2002.
- [5] Schroeder M, Cherchiglia A L, Souza V. Lightning current statistical analysis Measurements of Morro do Cachimbo Station- Brazil[C]//Proc. of the 26th International Conference on Ligh. Krakow, Poland, 2002: